



LH Series

High Pressure Centrifugal Pump



LH Series of Close-coupled High Pressure Centrifugal Pumps offer:

- Maximum inlet pressure of 600 psi
- Close-coupled, premium efficiency motors with JM frames
- Custom motor shaft made of AISI 4150 steel
- Custom bearings with an L10 life of 30,000 hrs
- Seals specifically designed for high pressure operation
- Lip seal flush option
- Standard stainless steel adapter

Ampco's LH Series of High Pressure Centrifugal Pumps offers significant space savings and eliminate alignment problems

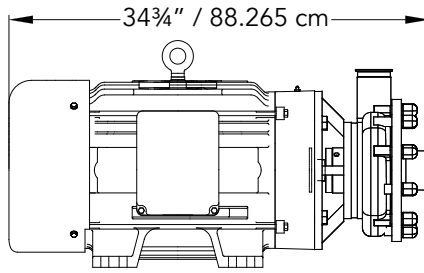

AMPCO LH V552
WITH 50 HP
324 JM MOTOR

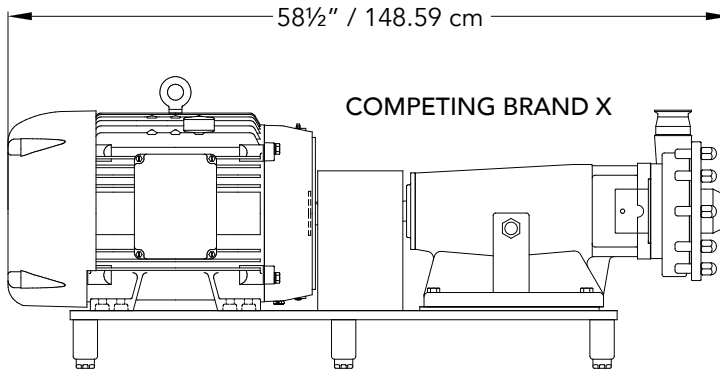

COMPETING BRAND X

LH Pumps are available in 3 models ranging from 15 HP to 75 HP

LH SERIES SUMMARY CURVE

Composite Performance Curve: 3500 RPM

Performance curve based on water.

A tolerance of +/- 5% applies to all figures.

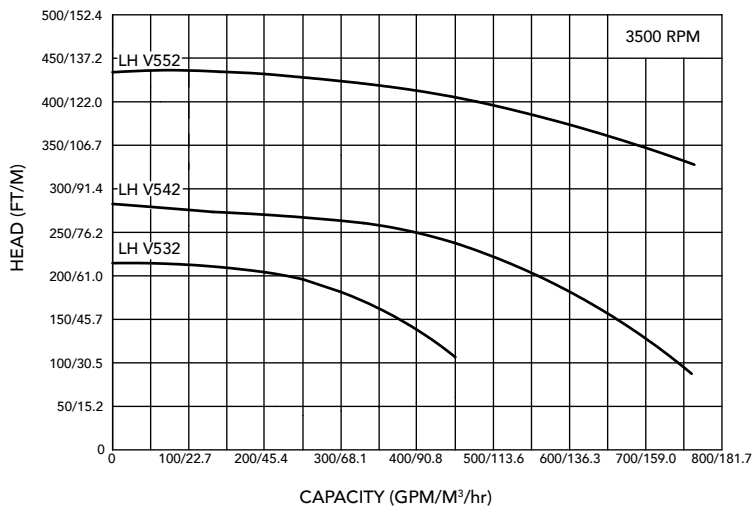

Visit www.ampcopumps.com for individual pump curves and dimensional drawings.

Ampco Pumps
Company

2045 W. Mill Road
Glendale, WI 53209
Phone: 800.737.8671
www.ampcopumps.com

Gewerbepark West II 7
76863 Herxheim Germany
Phone: +49 7276 5058515
info@ampcopumps.de

Ampco Pumps
GmbH